

HART™



Grill Cart

PROJECT PLAN

Finished Dimensions: 39-1/2"W x 36-1/2"H x 24"D

Skill Level: Intermediate

Materials

Item	Qty
4" x 4" x 8' Post*	2
2" x 8" x 8' Board*	2
2" x 3" x 8' Board*	2
1" x 4" x 8' Board*	3
1" x 3" x 8' Board*	1
3/4" x 3/4" x 36" Wood Square Dowel	2
2-1/2" Coarse Square-Head Pocket Hole Screw	
#8 x 1-1/2" Coarse Square-Head Pocket Hole Screw	
#6 x 3/4" Flat Head Phillips Wood Screw	12
#8 x 1-1/2" Flat Head Phillips Wood Screw	
#10 x 1-1/2" Flat Head Phillips Wood Screw	
#14 x 1-1/4" Slotted Hex Head Sheet Metal Screw	16
3" Polyurethane Swivel Caster with Brake	4
MPI Wood Large Pine Crate (See Website Below)	2
Wood Glue	
Sand Paper**: 150g, 220g & 320g	
Drill Bits: 3/16"	

* Board Dimensions are "nominal". Actual dimensions are smaller due to lumber industry standards. Cuts are actual length.

** Starting grit will depend on board surface condition, a rough surface will require starting with a coarse grit first.

 Grit is measured in the coarseness of the particles on the sandpaper. The lower the grit number, the coarser the paper. Heavy sanding would require 60 to 80 grit, medium sanding would require 120 to 220 grit, and finish sanding would require 320 to 400 grit. Super fine sanding would be 600 grit and higher.

 A select/premium board or plywood comes with a smoother surface finish. It is clear or has very few tight knots, and it will have straight and sharp edges. This grade of wood pairs well with other boards or panels better and requires less time to sand and finish.

MPI Wood Large Pine Crate, can be purchased on Walmart's website:

<https://www.walmart.com/ip/MPI-Wood-Large-Pine-Crate/46161817>

Tools Used



Miter Saw

or



Circular Saw



Drill/Driver



Jig Saw



Orbital Sander



20V 1.5Ah Battery



20V 4.0Ah Battery



Charger



Tape Measure



1/4" Socket Tool Set



Safety Glasses



Drill Bits



Countersink Bit



#2 Square Dr. Bit

Also Needed:

- Pocket Hole Jig
- (5) 36" Bar Clamps
- (6) 12" Bar Clamps
- (2) 6" Spring Clamps
- Framing Square
- Drawing Compass
- Wax Paper

Lumber Cut List

Board*	Description	Cut to	Qty
4" x 4"*	Post	31"	4
2" x 8"*	Cart Top	41"	4
2" x 3"*	Front & Back Support Frame	29-1/2"	4
2" x 3"*	Side Support Frame	14"	4
1" x 4"*	Bottom Shelf	20"	9
1" x 4"*	Center Support	17"	1
1" x 3"*	Center & Side Rails	17"	3
3/4" x 3/4"	Crate Rails	18"	4

* Board dimensions are "nominal." Actual dimensions are smaller due to lumber industry standards. Cuts are actual length.

Lumber & Sheet Layout Guide

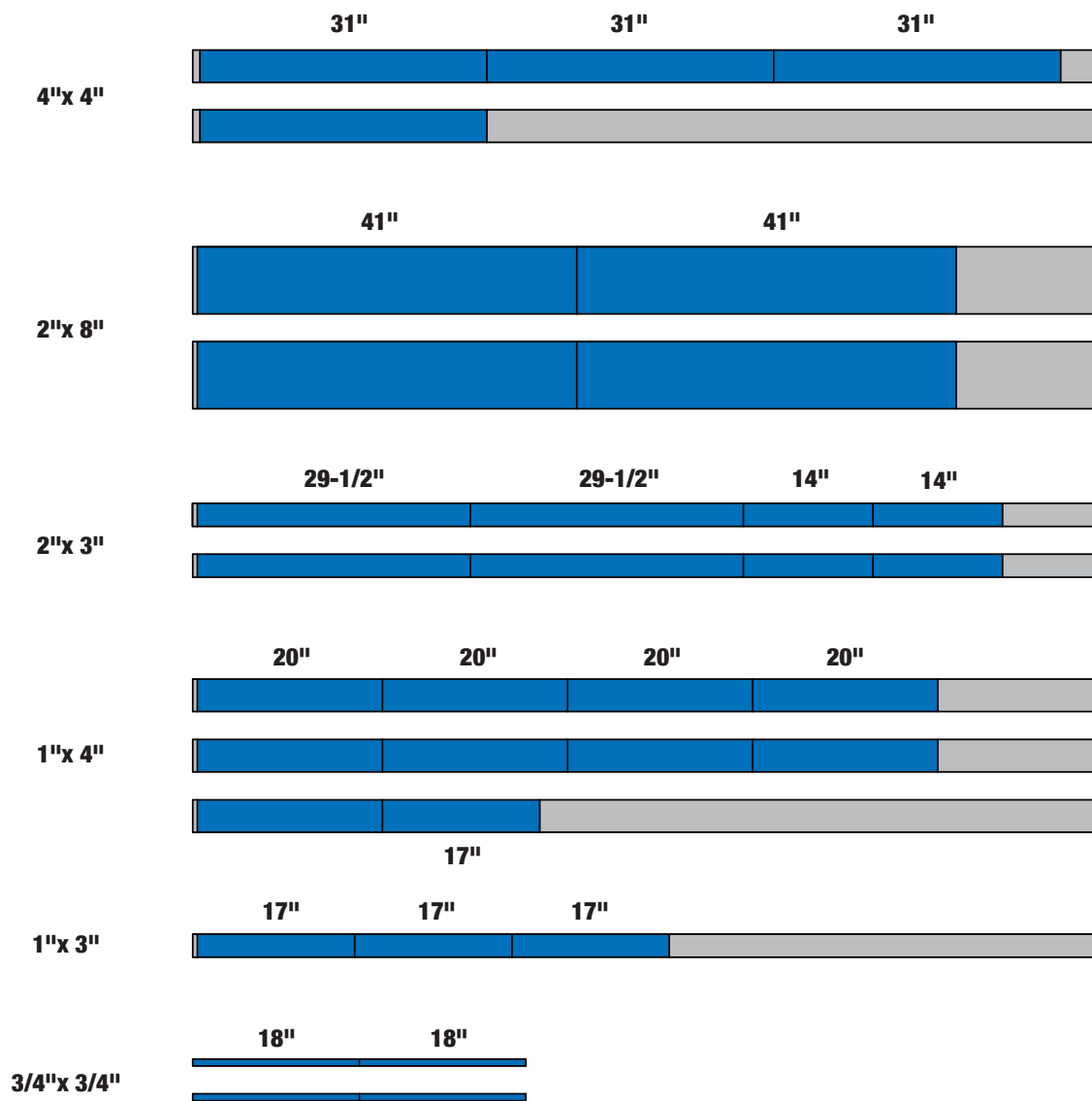

Lumber & Sheet Cut Layout Guide

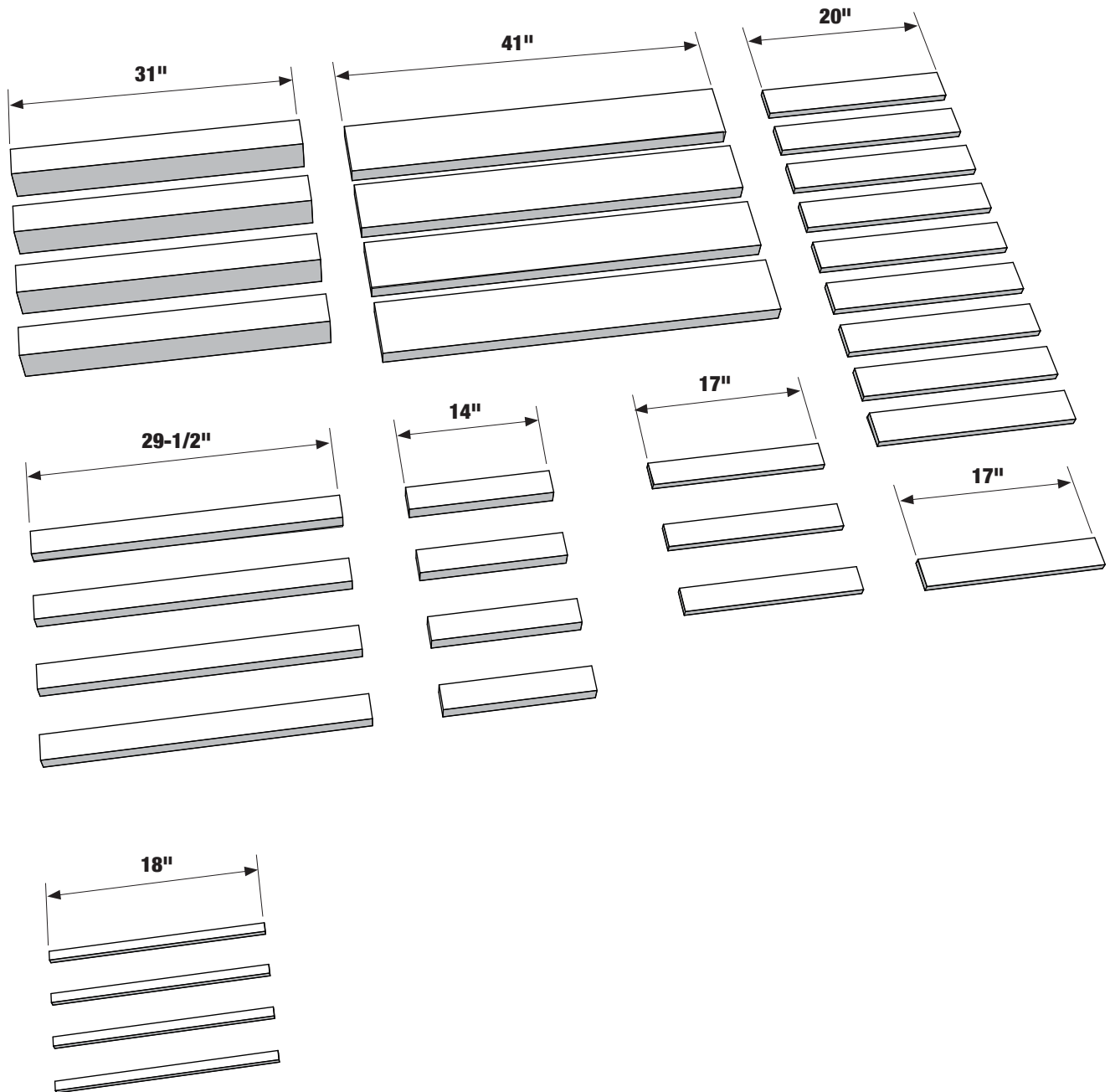

Assembly Instructions

Step 1

Cut out all material using the Lumber & Sheet Cut Layout Guide.



Step 2

Begin this project by working on the Grill Cart top. Use a Circular Saw to make a rip cut along one side of the board. A rip cut is when you cut parallel to the grain of the wood. Trim approximately 5/8" off (1) side of the (4) 2"x 8"x 41" boards.

On (2) of the boards, make a rip cut along the other side so the width of the board is 6" wide. We will rip cut the other (2) boards in Step 7.

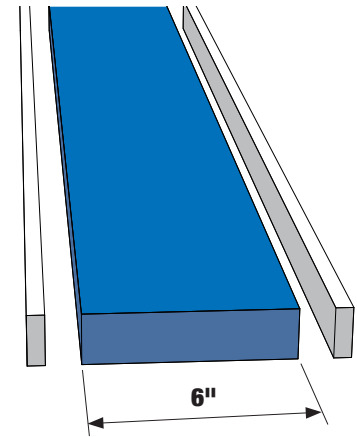

Step 3

Lay (3) of the 36" pipe clamps down on a flat surface. Make sure the boards and clamps fit well together before adding any glue. This is called a dry fit. You may need to elevate the (3) bottom clamps to allow clearance for blocks and bar clamps.

Glue Layout: Apply glue to the inside joints of both boards. The (2) unripped edges will go on the outside.

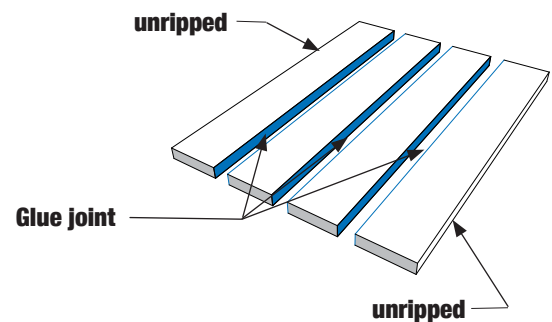

Step 4

With the (3) 36" bottom clamps in place, fix the boards so the (2) un-ripped sides are facing outwards.

Apply an even coat of glue to areas show in the Glue Layout on Step 3.

Adjust the tail clamps so they become snug with the board.

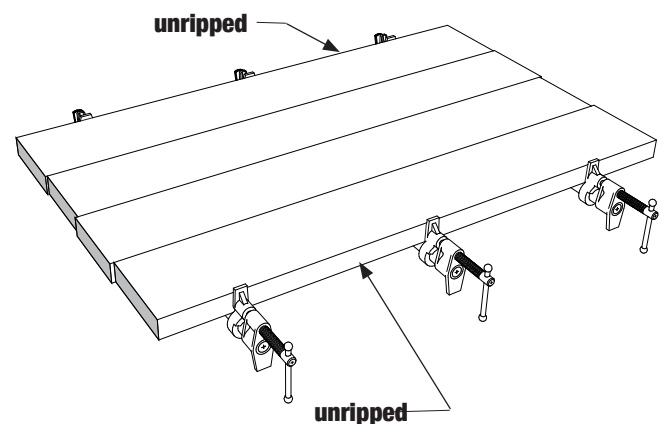

Assembly Instructions

Step 5

Equally space (2) pipe clamps on top and adjust tail clamps so they are snug.

The edges of the boards should be close together, but do not need to be perfectly aligned.

Starting from the center and working outward, give each head clamp a quarter turn to add a little pressure. Make sure clamps are perpendicular to the board as shown in the diagram to minimize shifting.

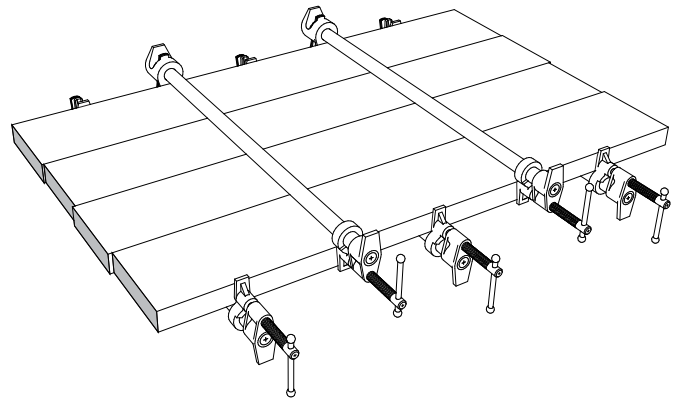

Step 6

Fold wax paper around both ends of the Grill Cart top. Add scrap blocks and (3) bar clamps on each end. This will keep the Grill Cart top flat.

Add more pressure to the head clamps. Again, start in the center and work outwards.

You will see some glue squeezing out. Use a slightly damp cloth and putty knife to clean off excess glue.

Allow glue to dry for 24 hours (follow instructions on the glue bottle).

This is a great time to start on the Grill Cart stand! See Step 9 and come back to Step 8 once glue has dried.

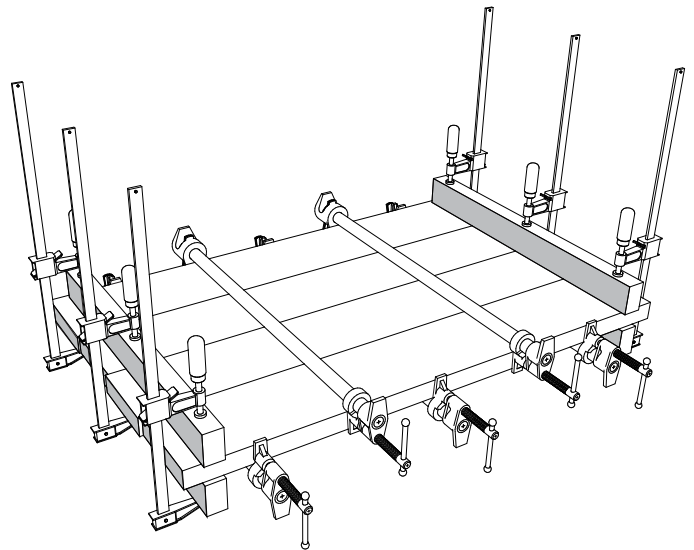

Step 7

After the glue has set, remove clamps, blocks, and wax paper. Clean off any dried glue on both sides.

You will need to trim your board on all four sides. One side may require more trimming than the other due to shifting during the gluing process. **The final dimensions for the top are 24" x 39-1/2", so trim accordingly.**

Use a Circular Saw to rip along the length of the Grill Cart top on both sides to give you a 24" depth.

Use a Framing Square to mark a straight line that is 90° to sides on both ends where you plan to trim.

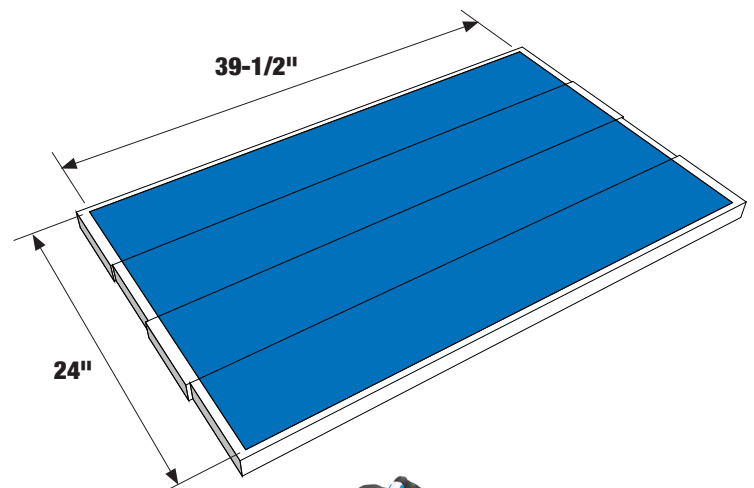

Assembly Instructions

Step 8

Before installing the Grill Cart top, sand the surface and soften the edges and corners to your desire.

Rougher finish – Use 60-80 grit sandpaper to hand sand with the grain of the wood.

Smoother finish – Use 60-80 grit sandpaper to remove scratches & imperfections.

Followed by using 120-220 grit to smooth.

Finish Sanding – Use 320-400 grit sandpaper

Super fine sanding – Use 600+ grit sandpaper

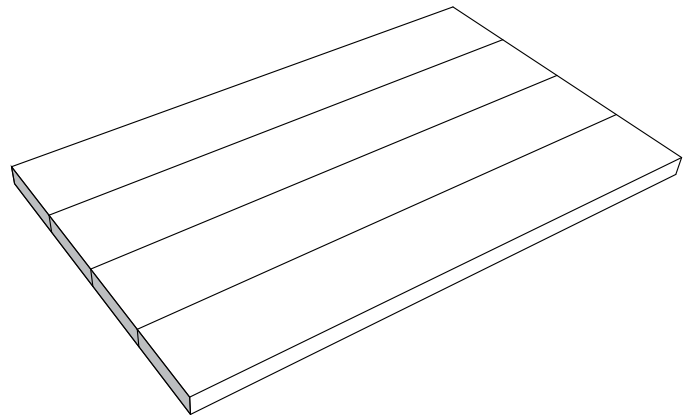

Step 9

Start by drilling (2) pocket holes in the center of each end of the (2) 29-1/2" support frame boards and the (2) 14" support frame boards. Use the (A&C) guide holes (fig-1).

Then take the (2) 29-1/2" boards and mark a point 3" and 10-3/4" from both ends. Drill pocket holes perpendicular to the already drilled pocket holes using the (B) guide hole (fig-2).

Repeat this process on (2) of the 14" boards.

These boards will become the support frame boards to attach to the Grill Cart top.

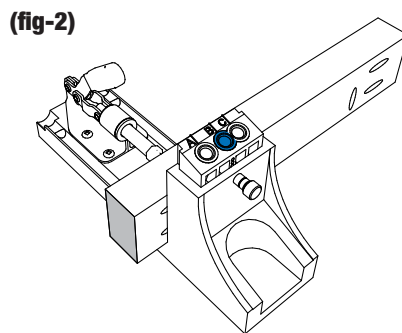
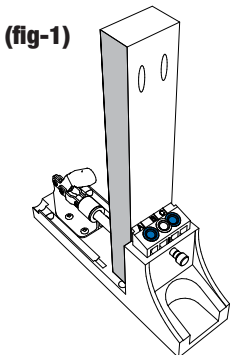
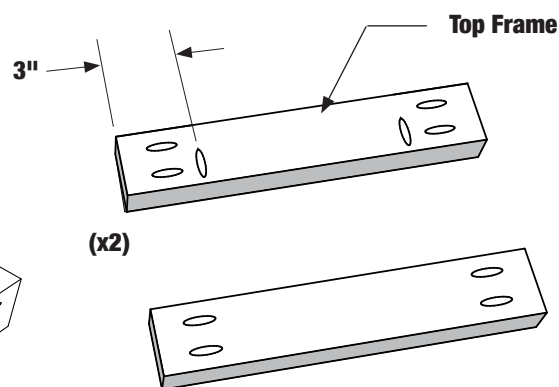
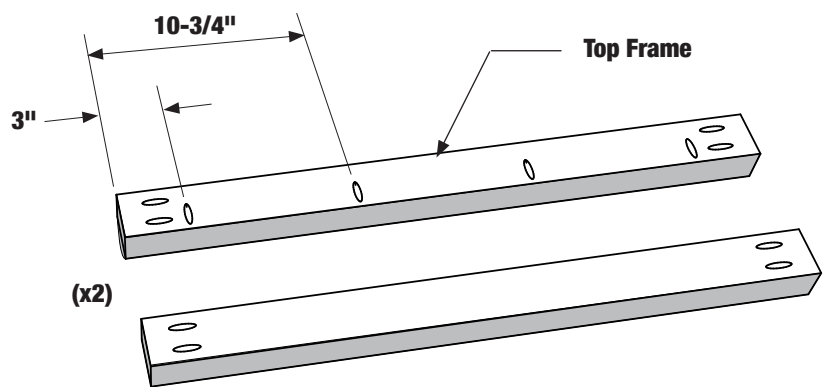

Step 10

On (1) of the 17" center rail boards, find the center line (☉). Measure and mark points in 3-3/4" increments from the center line.

Drill countersink holes at each point.

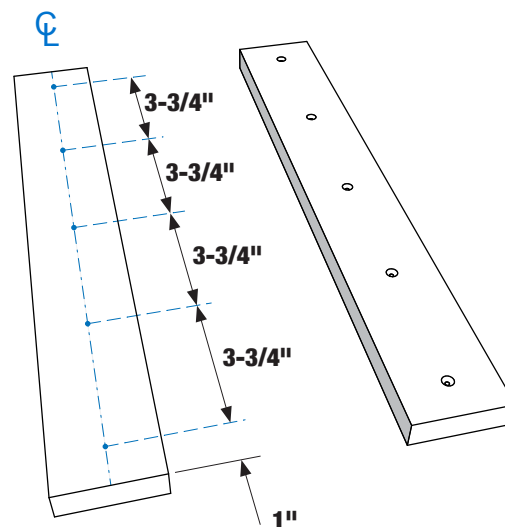

Step 11

Take the 17" center support board and mark a line 5/8" from each edge as shown in the diagram.

Drill pocket holes using the (A&B) guide holes. Flip the board around and repeat on the other end. Pocket holes will be offset to one side of the board.

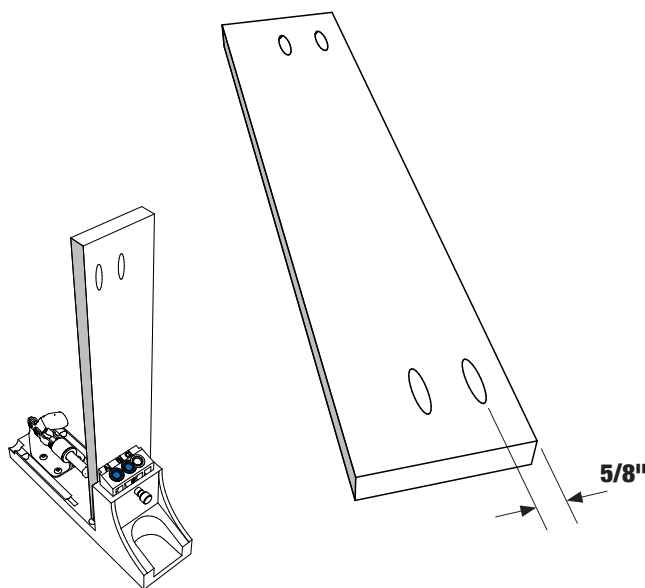

Step 12

Center the 17" center rail over the 17" support board as shown in the diagram. Attach the two pieces using #8 x 1-1/2" wood screws.

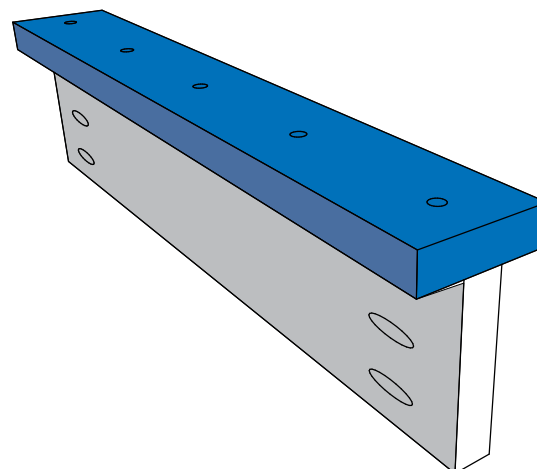

H **Tip -** To prevent the boards from splitting, align them in position and clamp them first. Use the top board as a template on where to drill. The hole depth will equal the length of screw. The hole diameter will match the shaft size of the screw, not the thread diameter.



Step 13

Use a Jig Saw to cut a notch out of end of the (2) 17" side rails. Follow the diagram to the right for measurements.

Find the center and drill a countersink hole 3/4" from each end of the 17" side rail (fig-1).

Next, drill pocket holes at each end on the same side as the notch. You will need to raise the entire pocket hole jig because the notch is longer than the jig. The extended piece of the notch will run alongside the pocket hole jig. Drill using the (A) guide hole when the notch is on the left side (fig-2&3).

Flip the board over and use the (C) guide hole when the notch is on the right side of the pocket hole jig (fig-4).

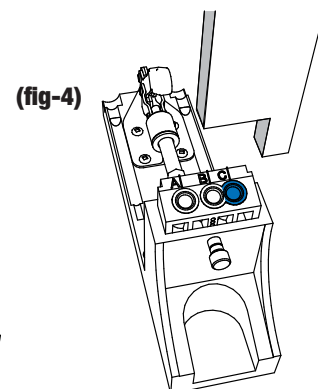
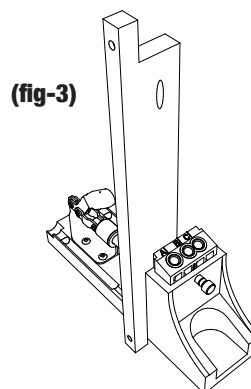
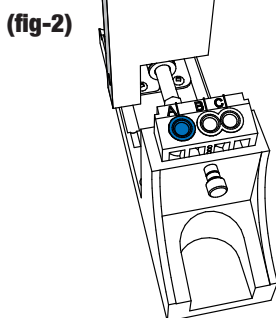
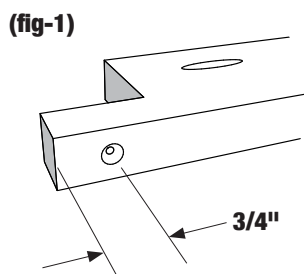
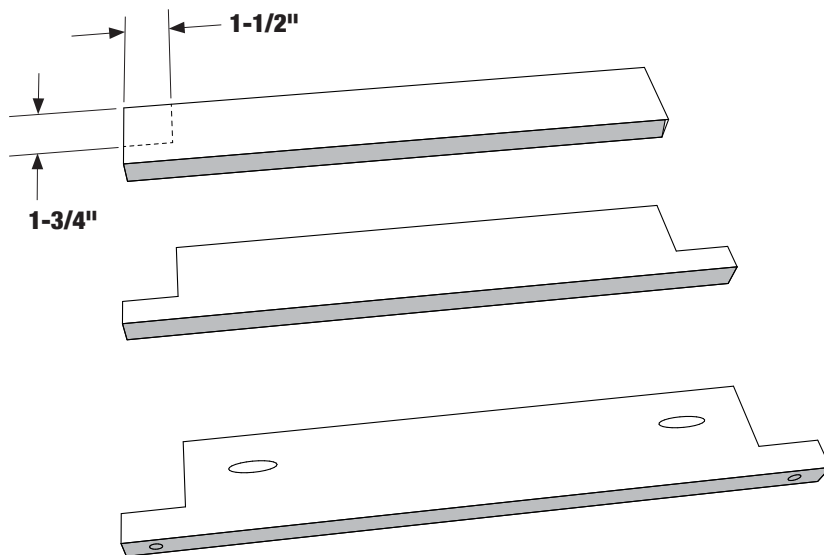

Step 14

On (7) of the 20" bottom shelf boards, measure and mark for countersink holes. Measure 3/8" from the end and mark (2) points that are 1-3/4" apart and equally spaced from the sides. Do this on both ends.

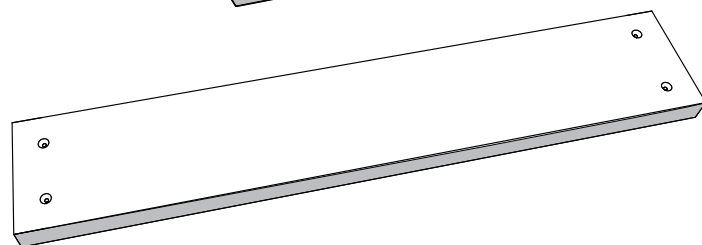
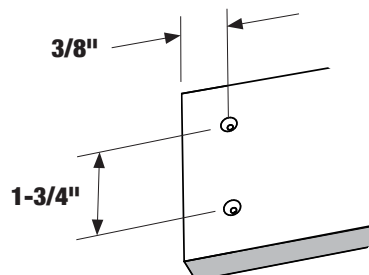

Step 15

The other (2) 20" bottom shelf boards require notches at each end. Use a Jig Saw to cut a 3" x 3" notch. .

Find center (C) and measure 6-1/4" on both sides and 3/8" from the edge.

Drill countersink holes at these (3) points.

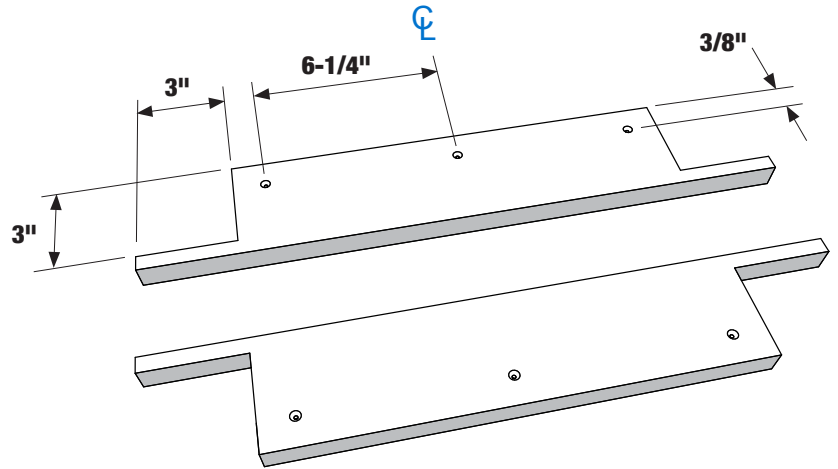

Step 16

Align edges of the 14" side support boards and the 4"x 4" posts. Place a 1/2" shim under the support board to raise it.

Attach support frame boards to posts with 2-1/2" pocket hole screws.

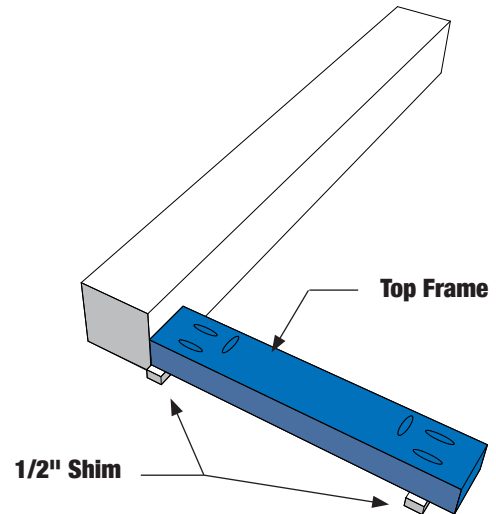

Step 17

Place 1/2" shims under all support frame boards. The bottom frame boards need to be 2" from the end of the 4"x 4" post. Attach posts with 2-1/2" pocket hole screws.

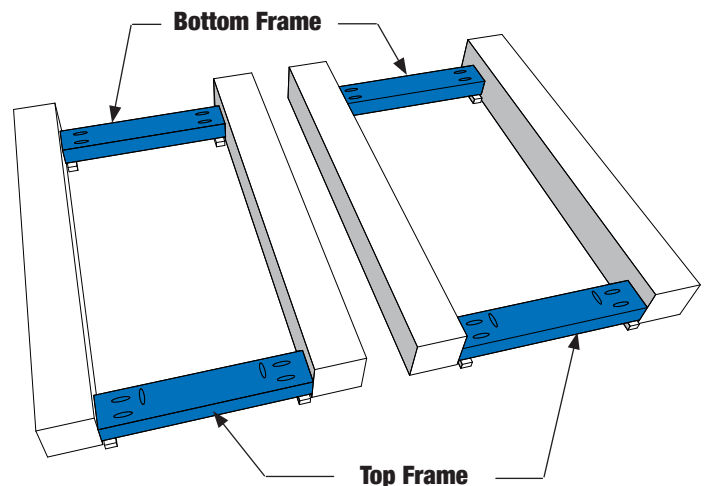
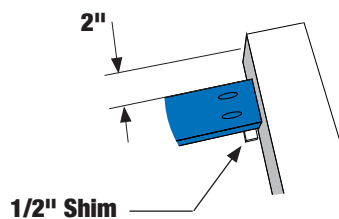

Step 18

Place the side frames built in Step 17 upright. Take a top and bottom 29-1/2" support board and raise it 1/2" with shims. The top board is even with the edges of the side frames. The bottom board is offset 2" from the edge of the side frames.

Attach with 2-1/2" pocket hole screws.

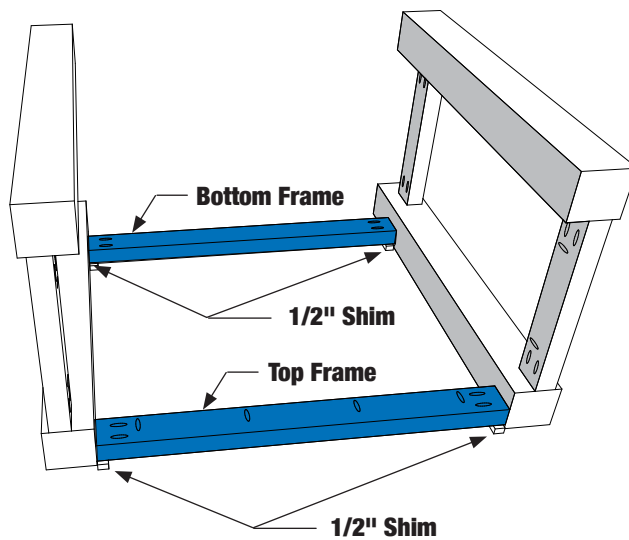

Step 19

Follow the same procedure in Step 18 to attach the back support frame boards.

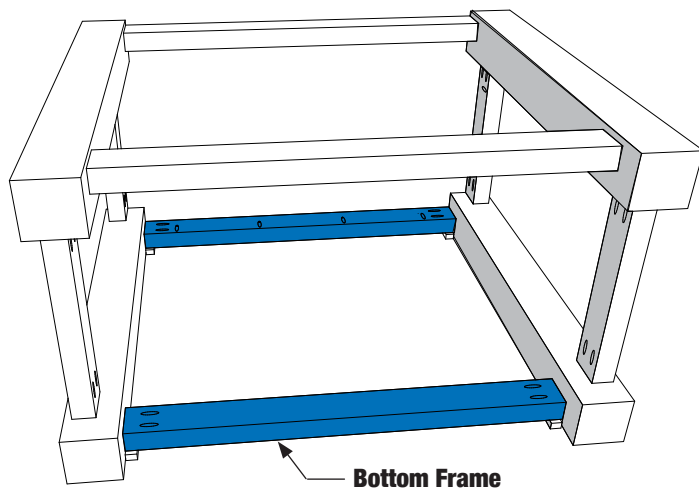

Step 20

Stand assembly upright. Find the mid-point of the top front and back support frames.

Attach the 17" center support rail with 1-1/2" pocket hole screws. Make sure top surfaces are even.

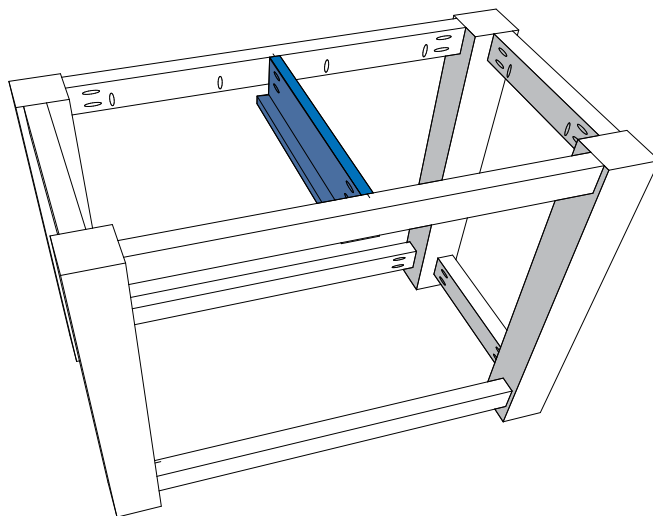

Step 21

Place the two 20" boards with notches on each end around the bottom posts. Then add the middle boards. Space the boards evenly (approximately 1/2" apart). Attach boards with #10 x 1-1/2" wood screws.

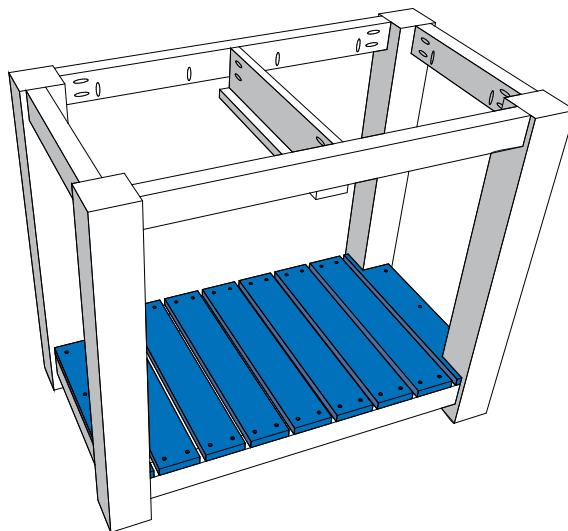

Step 22

Place the cart frame on the bottom side of the cart top. Center the frame on all sides.

When centered, the cart top should leave a 1-1/2" edge on both sides of the 4" x 4" posts.

Attach with 1-1/2" pocket hole screws.

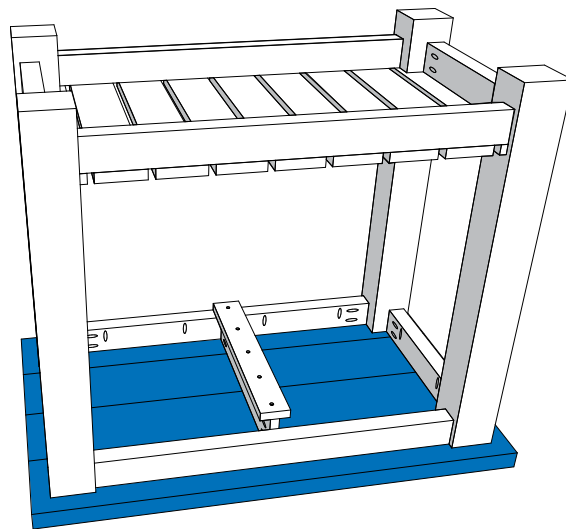
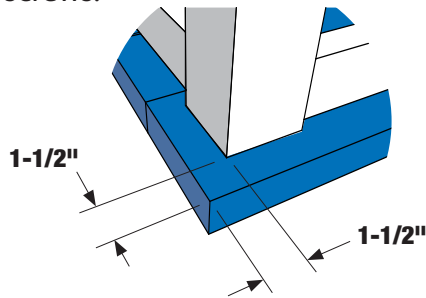

Step 23

The side rails for the box should be at the same height as the center rail installed in Step 20 so the boxes will slide in evenly. Install the side rail 1" from the edge of the support frame as shown in the diagram.

Attach the side rail with the #8 x 1/2" wood screws through the countersink holes first. Then attach 1-1/2" pocket hole screws on the sides.

Repeat this step to attach the side rail on the other side of the cart.

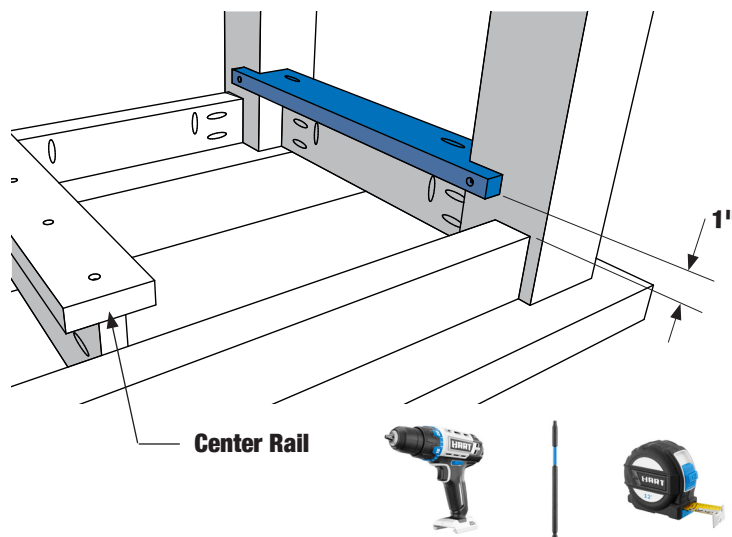

Step 24

Place casters on the bottom of the cart. Use the holes in the caster mounting plate as a template. Pre-drill (4) 3/16" holes 1" deep.

Mount casters to post using #14 1-1/4" hex head screws.

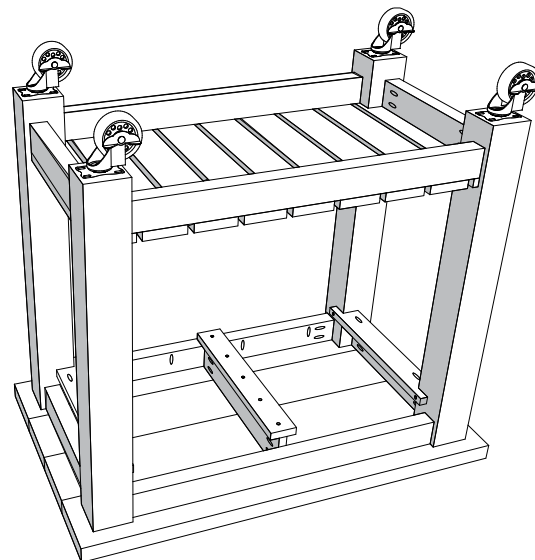
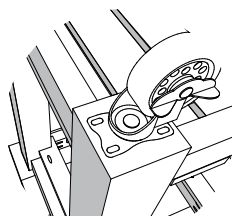

H Tip - Wrap masking tape to set the depth of the hole. When the tape meets the wood, stop drilling.



Step 25

On each side of the crate, find the mid-point on the top slat and mark center. Mark a point 3/8" from the top and 7" from the center line on both sides.

Align the 3/4"x 3/4" x 18" rails to the top edge of the crate slats. Clamp the rails to the crates with the 6" Spring Clamps.

Drill countersink holes at the points marked.

Attach with the #6 x 3/4" wood screws

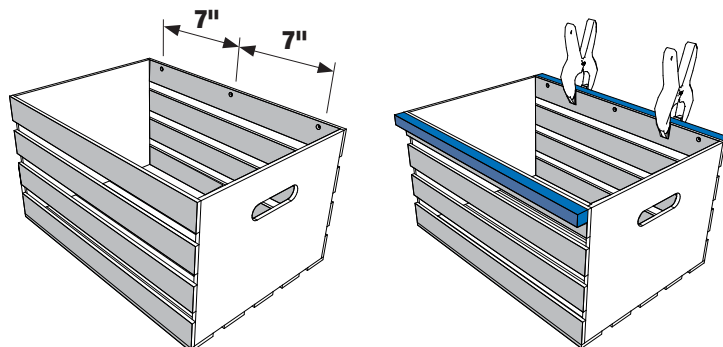

Step 26

Slide crates into rails on the Grill Cart.

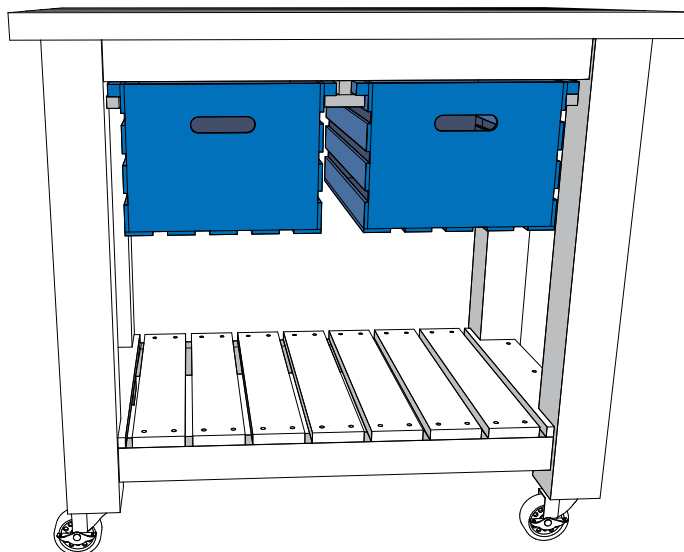

Step 27

Sand and finish to your desire.

Project Complete!

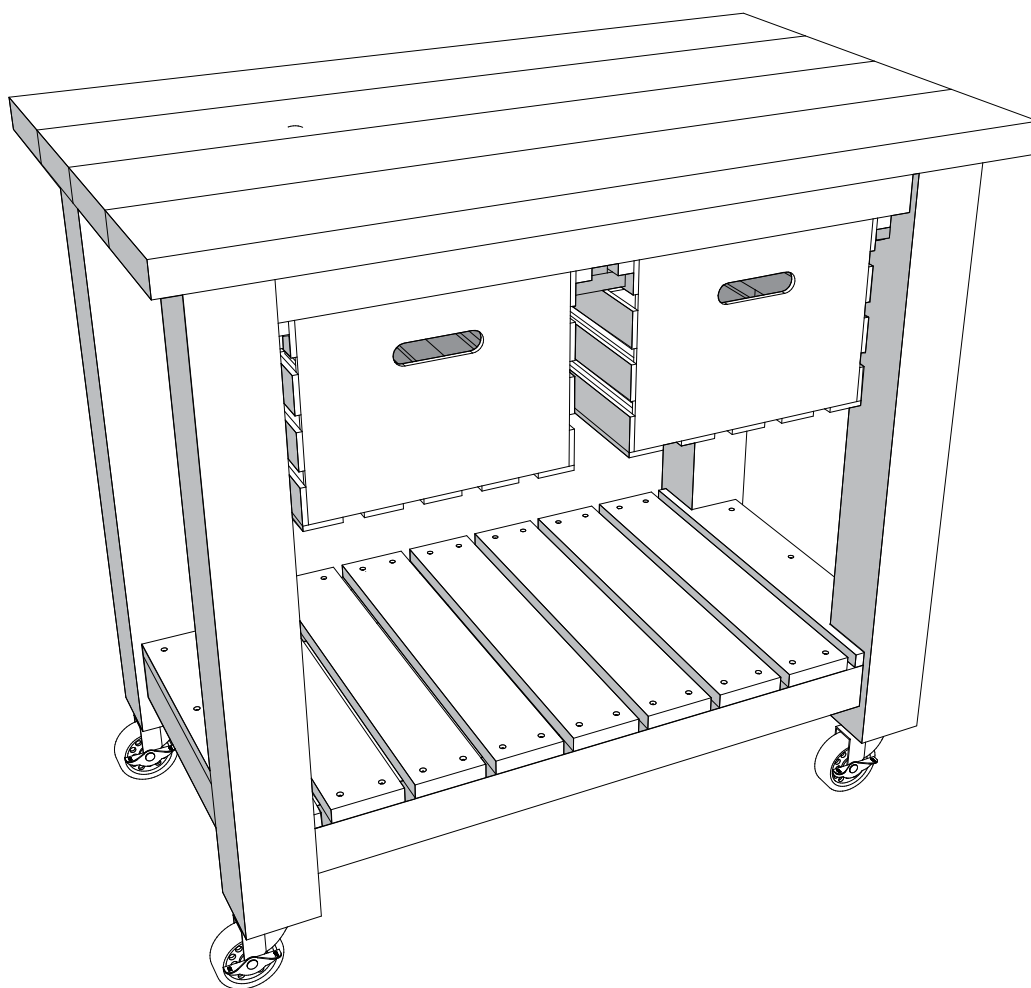

H **Rougher finish** – Use 60-80 grit sandpaper to hand sand with the grain of the wood.

Smoother finish – Use 60-80 grit sandpaper to remove scratches & imperfections.

Followed by using 120-220 grit to smooth.

Finish Sanding – Use 320-400 grit sandpaper

Super fine sanding – Use 600+ grit sandpaper

H **Tip** - Before using the Grill Cart, treat the wood with a food-safe oil. Be sure to follow manufacturer instructions.

